

FRONT VIEW II SCALE 1:5

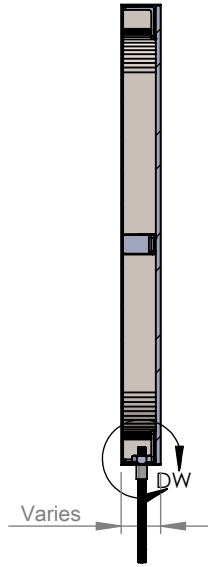

SECTION VIEW A-A II SCALE 1:5

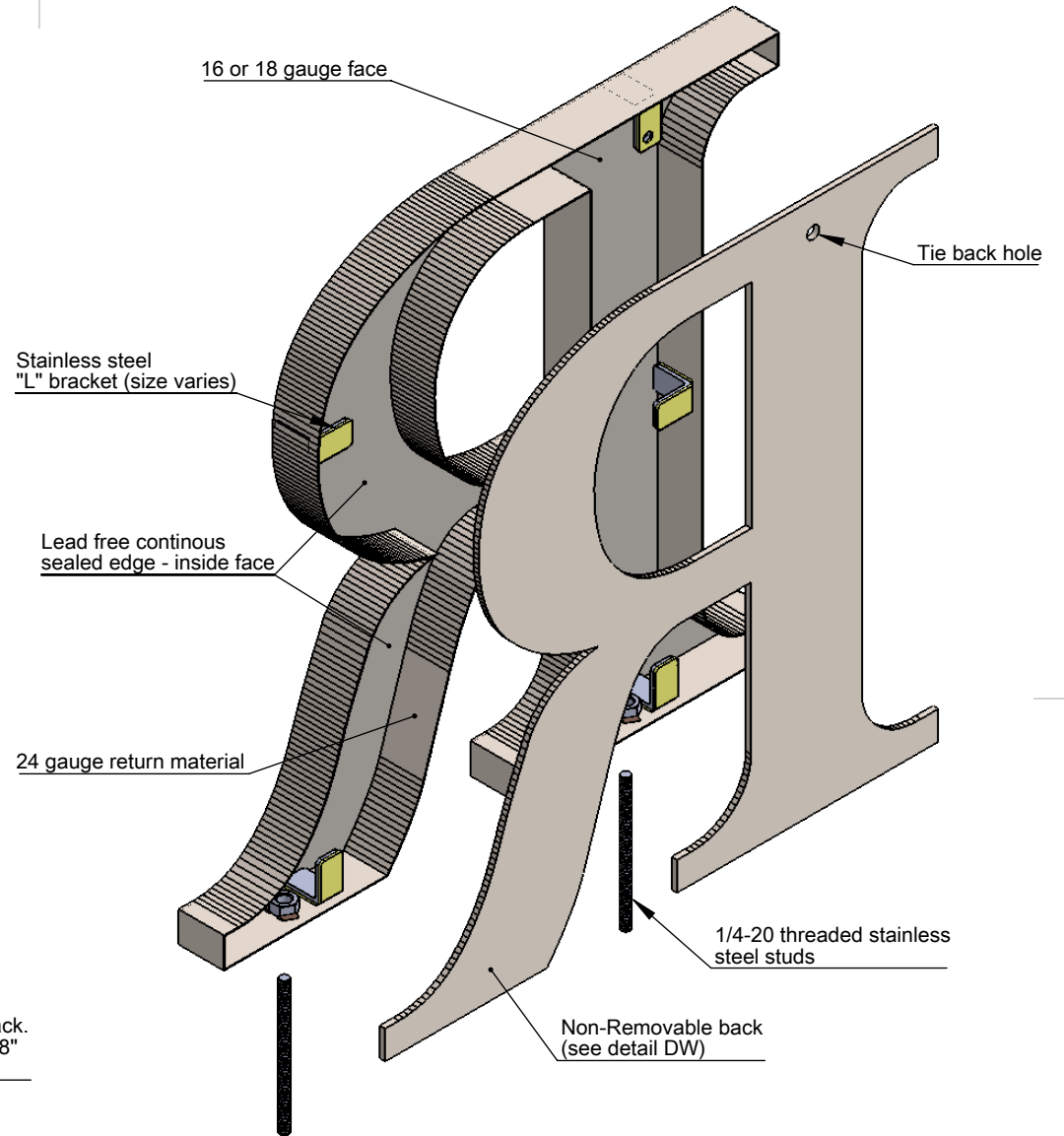

ISOMETRIC BACK VIEW II SCALE 1:3

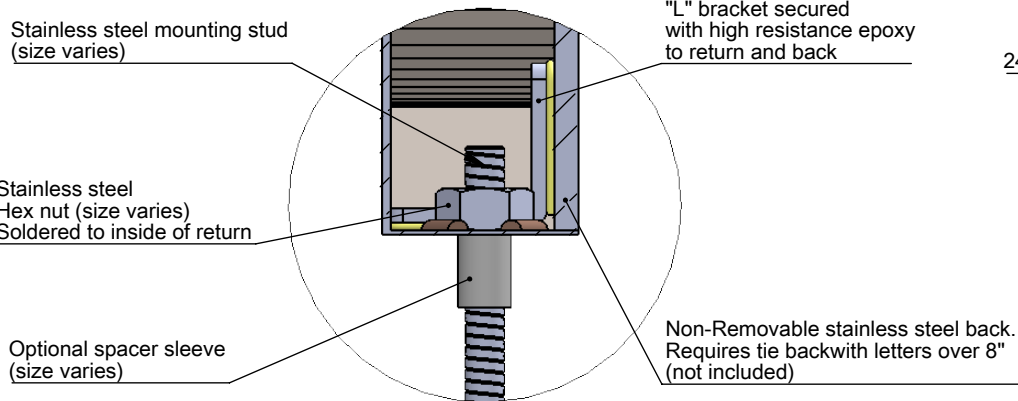

DETAIL DW II SCALE 1:1

- NOTES:**
- Tie backs required (not supplied) on letters > 8" high
 - Return grain will run around the perimeter of the letter

BACK OPTIONS

- Stainless steel - same gauge as face.

MATERIAL OPTIONS

- Standard - 304 prefinished stainless steel
- Optional - 316 prefinished stainless steel (more corrosion resistant)
- 304 prefinished stainless with titanium coating



TITLE: **METAL FACE WITH NON-REMOVABLE BACK
BOTTOM STUD MOUNT**

MATERIAL: **STAINLESS STEEL**

PRODUCT TYPE: **FABRICATED METAL**